

## Mobile Anlagen 2 Fraktionen

## Mobile machines 2 fractions

Grundmaschine	2F Auflieger/2F Anhänger
Beschreibung	Sattelaufleger/3-Achs-Anhänger für 80 km/h gem. StVO, mit ABS
Gesamtgewicht	ca. 16.000 kg

Base machine	2F king pin/2F tow bar
Description	king pin/3-axle-tow bar for 80 km/h with ABS
Total weight	approx. 16.000 kg

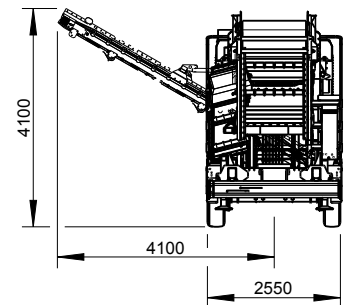
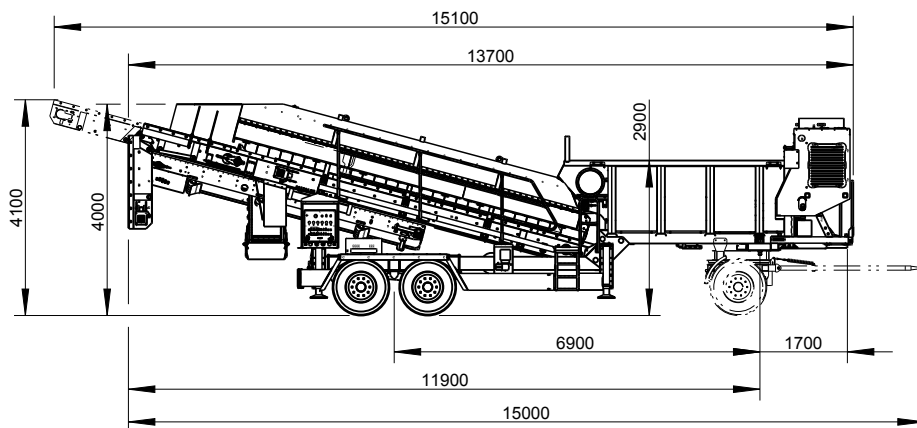

Grundmaschine	2F Raupe
Beschreibung	Raupenfahrwerk
Gesamtgewicht	ca. 22.000 kg

Base machine	2F crawler
Description	crawler tracks
Total weight	approx. 22.000 kg

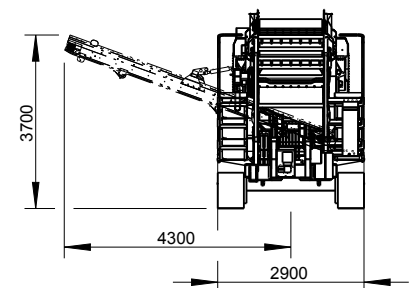
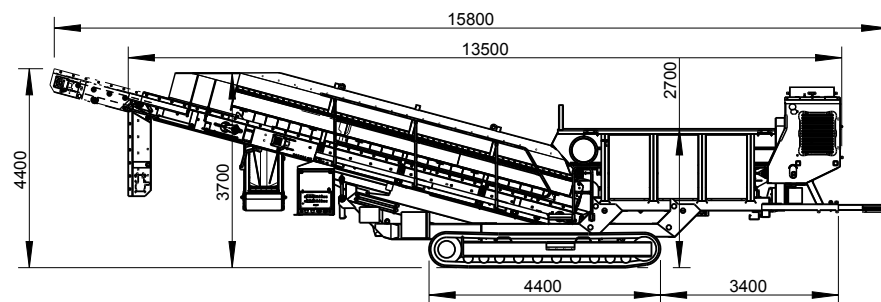

Antrieb	Dieselhydraulisch
Leistung	97 kW bei 2.000 U/min
Abgasnorm	Entsprechend der neuesten Abgasnorm
Hubraum	4,4 Liter
Kraftstofftank	300 Liter
Bunkervolumen	bis zu 7,5 m <sup>3</sup>

Drive	diesel hydraulic
Power	97 kw at 2.000 rpm
Emission	according to the latest exhaust emission standard
Engine displacement	4,4 liter
Fuel tank	300 liter
Hopper volume	up to 7,5 m <sup>3</sup>

Siebdeck	
Breite	1.250 mm
Länge	6.900 mm
Fraktionen	10 – 200 mm
Sterngröße	300, 230, 216 oder 170 mm
Sterndrehzahl	0 – 230 U/min stufenlos regelbar

Screen deck	
Width	1.250 mm
Length	6.900 mm
Fractions	10 – 200 mm
Star size	300, 230, 216 or 170 mm
Star speed	0 – 230 rpm continuously variable

Technische Änderungen vorbehalten!

Technical alterations reserved!

## Neuenhauser Maschinenbau GmbH

Hans-Voshaar-Straße 5 • D-49828 Neuenhaus • Germany  
 Telefon +49 (0) 5941 604-279 • Telefax +49 (0) 5941 604-323

E-Mail: [info@neuenhauser-umwelttechnik.de](mailto:info@neuenhauser-umwelttechnik.de)  
[www.neuenhauser-umwelttechnik.de](http://www.neuenhauser-umwelttechnik.de)

## Mobile Anlagen 3 Fraktionen

## Mobile machines 3 fractions

Grundmaschine	3F Auflieger/3F Anhänger
Beschreibung	Sattelaufleger/3-Achs-Anhänger für 80 km/h gem. StVO, mit ABS
Gesamtgewicht	ca. 19.000 kg

Base machine	3F king pin/3F tow bar
Description	king pin/3-axle-tow bar for 80 km/h with ABS
Total weight	approx. 19.000 kg

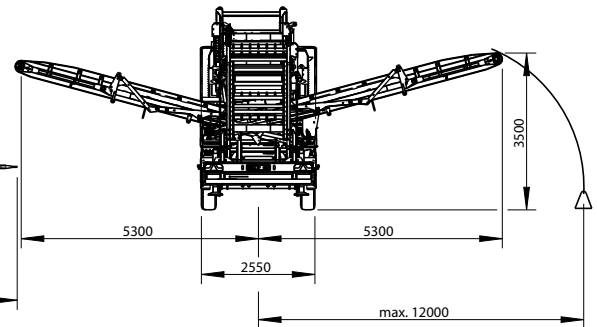
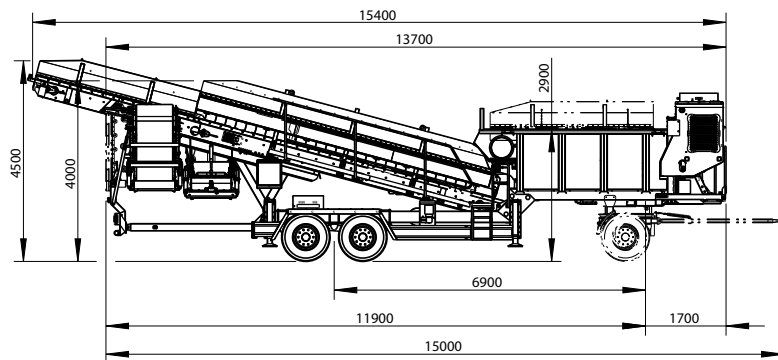

Grundmaschine	3F Raupe
Beschreibung	Raupenfahrwerk
Gesamtgewicht	ca. 24.000 kg

Base machine	3F crawler
Description	crawler tracks
Total weight	approx. 24.000 kg

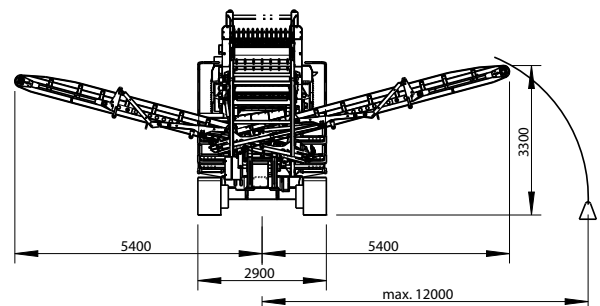
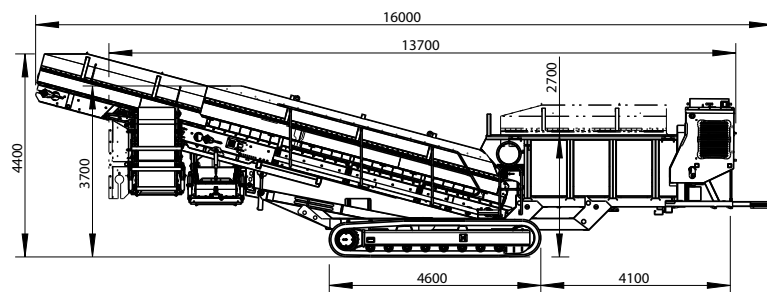

Antrieb	Dieselhdraulisch
Leistung	129 kW bei 2.000 U/min
Abgasnorm	Entsprechend der neuesten Abgasnorm
Hubraum	6,6 Liter
Kraftstofftank	300 Liter
Bunkervolumen	bis zu 7,5 m <sup>3</sup>

Drive	diesel hydraulic
Power	129 kw at 2.000 rpm
Emission	according to the latest exhaust emission standard
Engine displacement	6,6 liter
Fuel tank	300 liter
Hopper volume	up to 7,5 m <sup>3</sup>

	Siebdeck Feinfraktion	Siebdeck Mittelfraktion
Breite	1.250 mm	1.250 mm
Länge	6.900 mm	3.700 mm
Fraktionen	10 – 200 mm	28 – 200 mm
Sterngröße	300, 230, 216 oder 170 mm	300 mm
Sterndrehzahl	0 – 230 U/min stufenlos regelbar	0 – 180 U/min stufenlos regelbar

	Screen deck fine fraction	middle size fraction
Width	1.250 mm	1.250 mm
Length	6.900 mm	3.700 mm
Fractions	10 – 200 mm	28 – 200 mm
Star size	300, 230, 216 or 170 mm	300 mm
Star speed	0 – 230 rpm continuously variable	0 – 180 rpm continuously variable

Technische Änderungen vorbehalten!

Technical alterations reserved!